

# 6" LED IC Airtight Super Sloped Ceiling Single Wall New Construction Housing - EL971ICA



ELCO Slant allows for installation in sloped ceilings ranging from 2/12 (10°) to 12/12 (45°). Can be used in insulated ceilings. Fits in 2" x 8" joist construction.

## Features

- 6" Super Sloped New Construction Single Wall Housing.
- IC Airtight for use in insulated ceilings.
- California Title 24 (JA8-2016-E).

## Specifications

<b>Wattage</b>	24W
<b>Voltage</b>	120V
<b>Damp Location Listed</b>	

## Dimensions

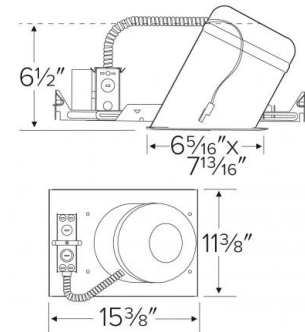

## Technical Details

### Construction:

- IC Rated for Direct Contact with Insulation.
- Designed for use in 7/12 to 12/12 sloped ceiling.
- Housing adjusts in frame to accommodate up to 1 1/4" ceiling thickness.
- Aluminum housing for greater heat dissipation. Stamped galvanized steel frame.

**Installation:** Designed for ceiling plenums where 2x8 joists or taller are used. High strength hanger bars can easily be nailed to joists. Template for hole cutout is provided with each housing. Suitable for T-grid and drop ceiling applications. See installation sheet for detailed information.

**Junction Box:** Positioned to accommodate straight conduit runs. Seven 1/2" trade size conduit knockouts and four pry-out knockout slots for easy romex installation.

**Hanger Bars:** Pre-installed hanger bars with True Nail easy installation in regular lumber, engineered lumber, and Laminated Beams. Integral T-bar slots for easy installation in T-Bars. Spans up to 24" and can be repositioned 90°. Score lines allow for tool-free hanger bar size reduction. Integral leveling flange allows for single-person installation while aligning the housings with the joists.

### Electrical:

- Rated for 120V or 277V input.
- For 277V step down to 120V housing consult factory.

**Trims:** Compatible with EL761, EL762, EL763, EL764 Series LED Inserts.

### Listings:

- UL Listed for Damp Location.
- UL Listed for Direct Contact with Insulation and Combustible Material.
- UL Listed for Feed Through.
- AirTight: Per ASTM E-283.
- California Title 24 (JA8-2016-E).

**Warranty:** ELCO Products are built to last. 5-year Limited warranty.

## Product Numbers

Item	Watts	Voltage
EL971ICA	24W	120V