

EL492RICA

4" Line Voltage Remodel
Shallow Housing for LED Inserts

PROJECT INFORMATION:

Project Name: _____

Fixture Type: _____

Date: _____

DIMENSIONS

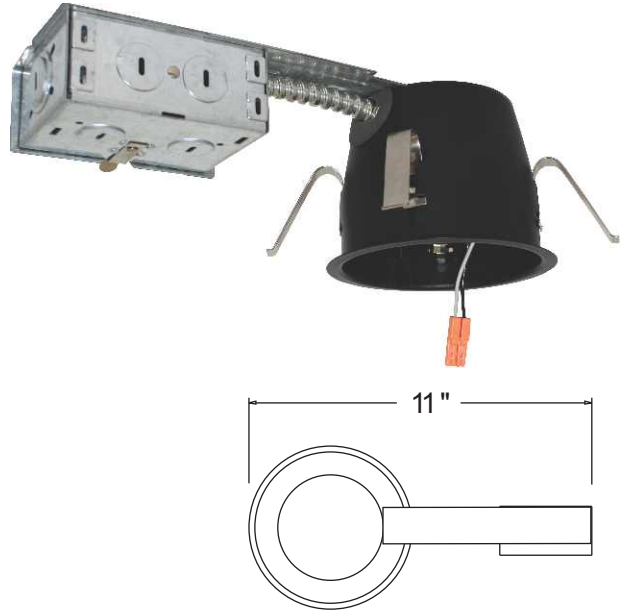
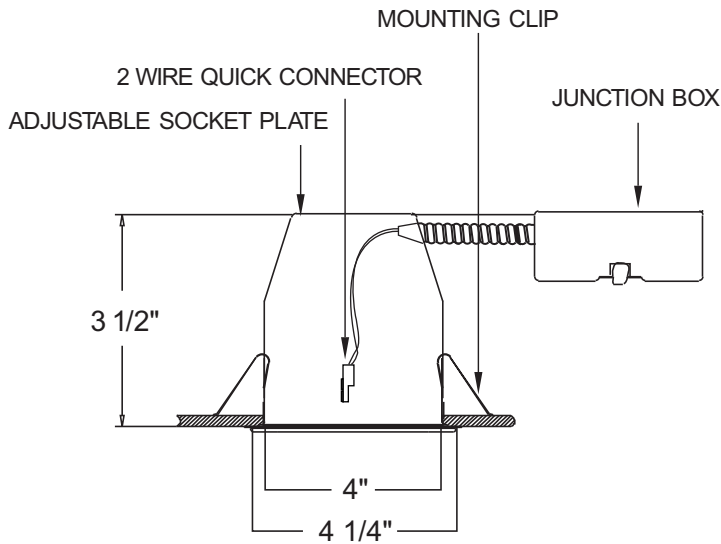

PRODUCT SPECIFICATIONS

- Single wall IC construction, for use in insulated ceilings.
- 3 1/2" height allows for use in 2 x 6 construction.
- Adjustable housing accommodates up to 1 1/4" ceiling thickness.
- Housing meets restricted air flow requirement (per ASTM E-283).
- CA Title 24 compliant (as low efficiency luminaire).
- Trims sold separately.

Lamp: 14W Max 120V

Lamp Holder: 2-wire quick connect terminal connector.

Labels: U.L. listed for damp locations
U.L. listed for feed through
U.L. listed for direct contact with insulation

INSTALLATION

Junction Box: Pre-wired junction box provided with 1/2" and 3/4" knockouts. Maximum (8) No. 12 AWG branch circuit conductors (4 in, 4 out). Junction box provided with removable access plates.

Mounting: (4) remodel clips secure housing and accommodate various ceiling thicknesses.

Mounting Frame: Stamped galvanized steel construction for corrosion resistance

CATALOG NUMBER

Example: EL492RICA

See trims page for variety of trims available