



Specifications

**AP 90-S SERIES**

Very Quiet Slim Fit Bathroom Fan

**Description:** Super quiet slim fit bathroom fan engineered for continuous run • Ceiling or wall mount • Suitable for new construction or remodeling • HVI certified • ENERGY STAR qualified • ETL listed for use in insulated ceilings (Type I.C.).

**Motor/Blower:** Permanently lubricated enclosed condenser motor engineered for continuous energy efficient operation; power rating 120v/60Hz; motor equipped with thermal shut off.

**Housing:** Rugged 26 GA galvanized steel; detachable 4" and 6" duct connector with built-in back draft dampener; 2 anti-vibration hanger bar brackets adjustable to 24" span included; designed for ceilings with a minimum of 6" clearance.

**Grille:** Contemporary design; low maintenance, wipe clean UV inhibiting polymeric resin; attaches to housing with torsion springs.

**Finishes:** White (W); Satin Nickel (SN); Oil Rubbed Bronze (OR).

**Installation:** Must be installed by a licensed professional. Complete installation instructions included.

**Warranty:** 6 Years

**Architect's Specifications:** Ventilation fan will be ceiling or wall mount, ENERGY STAR qualified and no more than 0.3 sones at 90 CFM as certified by HVI at 0.1 Ps (inches water gauge). Power consumption shall be no greater than 33 watts and ENERGY STAR rated with an efficiency rating of no less than 2.7 CFM/watt. The motor will be permanently lubricated, engineered for continuous operation. Duct diameter will be 4" or 6" round. Fan shall be ETL/cETL listed for tub/shower enclosure when used with GFCI branch circuit wiring and shall be ETL/cETL listed for use in insulated ceiling (Type I.C.). Fan shall be ASHRAE 62.2, LEED, CalGreen, and WA Ventilation Code compliant.

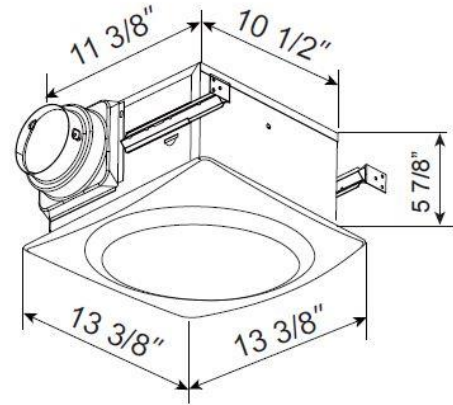

ETL Listed for installation over tub/shower enclosure with GFCI circuit wiring.



Model: AP 90 S Series	4" Duct	
Static Pressure (inches w.g.)	0.1	0.25
Air Volume (CFM)	90	68
Noise (sones)	0.3	n/a
Power Consumption (Watts)	33	32.3
Energy Efficiency (CFM/Watts)	2.7	2.1
Current (AMPS)	0.4	0.36
ENERGY STAR rated	Yes	
Grille Dimensions	13 3/8' x 13 3/8"	



Model	Qty	Comments	Project
			Location
			Architect
			Engineer
			Contractor
			Submitted by
			Date

# Aero Pure



## Specifications

### AP 120-S SERIES

Very Quiet Slim Fit Bathroom Fan

**Description:** Super quiet slim fit bathroom fan engineered for continuous run • Ceiling or wall mount • Suitable for new construction or remodeling • HVI certified • ENERGY STAR qualified • ETL listed for use in insulated ceilings (Type I.C.).

**Motor/Blower:** Permanently lubricated enclosed condenser motor engineered for continuous energy efficient operation; power rating 120v/60Hz; motor equipped with thermal shut off.

**Housing:** Rugged 26 GA galvanized steel; 2 anti-vibration hangar bar brackets adjustable to 24" span included; designed for ceilings with a minimum of 6" clearance.

**Duct:** Detachable 4" and 6" duct connector with built-in back draft dampener.

**Grille:** Contemporary design; low maintenance, wipe clean UV inhibiting polymeric resin; attaches to housing with torsion springs.

**Finishes:** White (W); Satin Nickel (SN); Oil Rubbed Bronze (OR).

**Installation:** Must be installed by a licensed professional. Complete installation instructions included.

**Warranty:** 6 Years

**Architect's Specifications:** Ventilation fan will be ceiling or wall mount, ENERGY STAR qualified and no more than 0.9 sones at 120 CFM as certified by HVI at 0.1 Ps (inches water gauge). Power consumption shall be no greater than 33 watts and ENERGY STAR rated with an efficiency rating of no less than 3.8 CFM/watt. The motor will be permanently lubricated, engineered for continuous operation. Duct diameter will be 6" round. Fan shall be ETL/cETL listed for tub/shower enclosure when used with GFCI branch circuit wiring and shall be ETL/cETL listed for use in insulated ceiling (Type I.C.). Fan shall be ASHRAE 62.2, LEED, CalGreen, and WA Ventilation Code compliant.

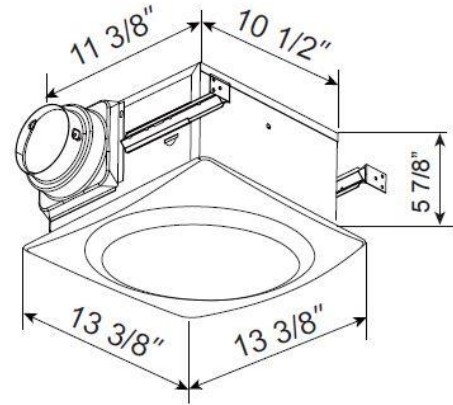

ETL Listed for installation over tub/shower enclosure with GFCI circuit wiring.



Model: AP 120 S Series	6" Duct	
Static Pressure (inches w.g.)	0.1	0.25
Air Volume (CFM)	126	111
Noise (sones)	0.9	n/a
Power Consumption (Watts)	33	32.3
Energy Efficiency (CFM/Watts)	3.8	3.4
Current (AMPS)	0.28	0.27
ENERGY STAR rated	Yes	
Grille Dimensions	13 3/8' x 13 3/8"	



Model	Qty	Comments	Project
			Location
			Architect
			Engineer
			Contractor
			Submitted by
			Date